

# PG UNION STRAIGHT REDUCER

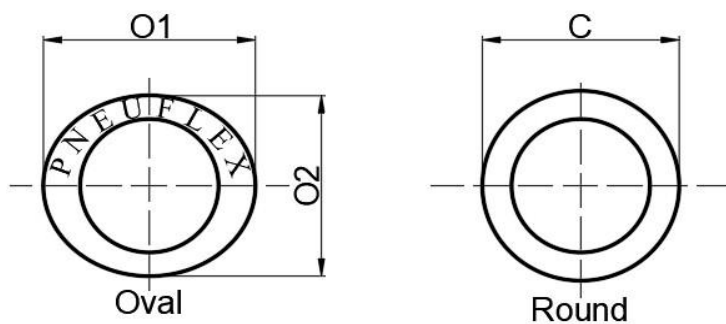
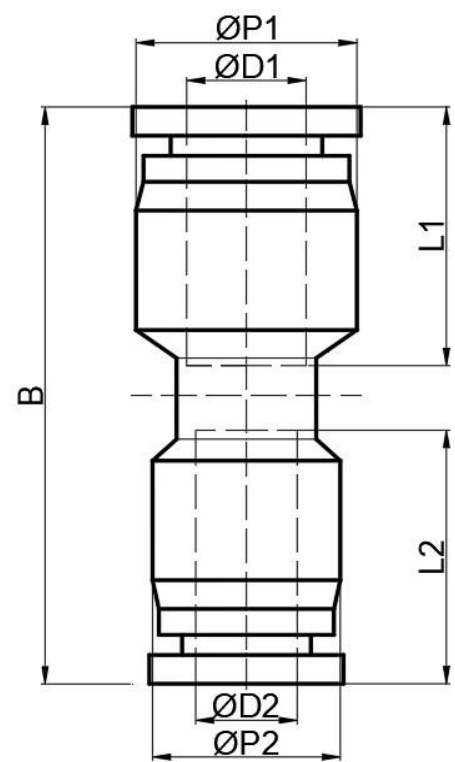

Model	Applicable Tubing ØD1	Applicable Tubing ØD2	ØP1	ØP2	B	L1	L2	O1	O2	C
PG 06-04	Ø6mm	Ø4mm	13.5	11	33	15.9	13.8	13.8 12	12.4 10.4	11.8 9.8
PG 08-04	Ø8mm	Ø4mm	15	13.5	37	19	13.8	16 12	13.8 10.4	13.8 9.8
PG 08-06	Ø8mm	Ø6mm	15	13.5	37.2	19	15.9	16 13.8	13.8 12.4	13.8 11.8
PG 10-06	Ø10mm	Ø6mm	19	15	42.5	21.8	15.9	19.5 13.8	17 12.4	16.8 11.8
PG 10-08	Ø10mm	Ø8mm	19	15	43.5	21.8	19	19.5 16	17 13.8	16.8 13.8
PG 12-06	Ø12mm	Ø6mm	21	19	46.5	22.8	15.9	23 13.8	20.5 12.4	19.8 11.8
PG 12-08	Ø12mm	Ø8mm	21	19	47	22.8	19	23 16	20.5 13.8	19.8 13.8
PG 12-10	Ø12mm	Ø10mm	21	19	47.3	22.8	21.8	23 19.5	20.5 17	19.8 16.8
PG 14-12	Ø14mm	Ø12mm	23	23	50	24	22.8	25 23	22 20.5	21.8 19.8
PG 16-12	Ø16mm	Ø12mm	26	23	50.5	24.7	22.8	26.5 23	24.5 20.5	23.8 19.8
PG 16-14	Ø16mm	Ø14mm	26	23	51	24.7	24	26.5 25	24.5 22	23.8 21.8
PG 5/32-1/8	Ø5/32"	Ø1/8"	11	11	33	13.8	13.8	12 12	10.4 10.4	9.8 9.8
PG 3/16-1/8	Ø3/16"	Ø1/8"	11	11	33	14.3	13.8	12 12	10.4 10.4	9.8 9.8
PG 3/16-5/32	Ø3/16"	Ø5/32"	11	11	33	14.3	13.8	12 12	10.4 10.4	9.8 9.8
PG 1/4-1/8	Ø1/4"	Ø1/8"	13.5	11	33	15.9	13.8	13.8 12	12.4 10.4	11.8 9.8
PG 1/4-5/32	Ø1/4"	Ø5/32"	13.5	11	33	15.9	13.8	13.8 12	12.4 10.4	11.8 9.8
PG 1/4-3/16	Ø1/4"	Ø3/16"	13.5	11	33	15.9	14.3	13.8 12	12.4 10.4	11.8 9.8
PG 5/16-5/32	Ø5/16"	Ø5/32"	15	13.5	37	19	13.8	16 12	13.8 10.4	13.8 9.8
PG 5/16-1/4	Ø5/16"	Ø1/4"	15	13.5	37.2	19	15.9	16 13.8	13.8 12.4	13.8 11.8
PG 3/8-3/16	Ø3/8"	Ø3/16"	19	15	42.3	22.8	14.3	19.5 12	17 10.4	16.8 9.8
PG 3/8-1/4	Ø3/8"	Ø1/4"	19	15	42.5	22.8	15.9	19.5 13.8	17 12.4	16.8 11.8
PG 3/8-5/16	Ø3/8"	Ø5/16"	19	15	43.5	22.3	19	19.5 16	17 13.8	16.8 13.8
PG 1/2-5/16	Ø1/2"	Ø5/16"	21	19	47	22.8	19	23 16	20.5 13.8	19.8 13.8
PG 1/2-3/8	Ø1/2"	Ø3/8"	21	19	47.3	22.8	22.3	23 19.5	20.5 17	19.8 16.8